



New Mexico
Gray Water Guide

INTRODUCTION

You might have a family member or friend who is old enough to remember using a hand pump to draw water or who may have had to haul water from a distant supply. Ask them how many times water was used before pouring it on a tree near the house or onto the kitchen garden out the back door. Using precious water just once would have been considered wasteful and just not done in those days.

Nowadays we take our water supply very much for granted. We turn on the tap and there it is in fresh hot or cold abundance. We let it run while we brush our teeth, look at ourselves in the mirror, talk to a family member or just daydream. It is all so easy and so inexpensive that we rarely give water much thought.

In recent years, with growing populations and limited amounts of fresh water available, water conservation, or the efficient use of water, has assumed greater importance in our lives. People are looking for ways to use less water or to use water more than once. This leads some people to wonder about just how or if they should reuse gray water in their gardens.

We hope the information on the following pages will help you decide whether use of your gray water for landscape irrigation is right for you. We also hope it will assist you in determining whether it is possible or feasible for you to make economical use of your gray water.

“In 2003, the New Mexico Legislature changed state law (Section 74-6-2 NMSA 1978) to make it easier for New Mexico residents to reuse gray water. The results of these efforts are a set of rules for residential gray water use that are simple and straightforward. The new rules are contained in this publication on page 21.”

What is Gray Water?

Gray water is wastewater from your laundry, bathtubs, showers, and bath sinks (lavatories). Water from your clothes washing and bathing is, for the most part, an excellent source of water to irrigate your residential landscapes and compost piles.

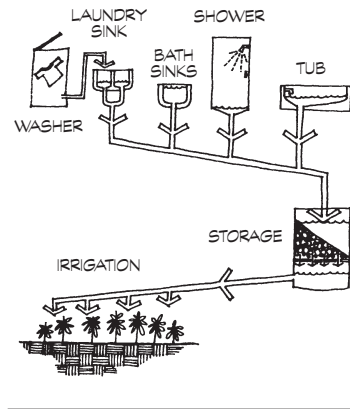

Graywater System Schematic

What Gray Water is Not . . .

For the purpose of regulation in New Mexico, water from kitchen sinks and dishwashers is not considered gray water. The reason for this is the potential for increased health risks associated with the organic matter commonly associated with food preparation and cooking.

Water from your toilet, which is considered blackwater, is not suitable for any reuse in or around your home.

Gray water is not to be confused with reclaimed or effluent water which is water from a municipal sewer system that has been

treated and then delivered to high-volume water users such as golf courses, parks and playgrounds via a separate distribution system.

Can I Use My Gray Water?

In 2003, the New Mexico Legislature changed a state law and the New Mexico Environment Department (NMED) issued new regulations for the use of residential gray water. These new rules make it possible and feasible for the general public to use their gray water for landscape irrigation. The full text of the new straightforward, common sense rules can be found on page 21 of this booklet.

The new rules state you may legally use gray water from your clothes washers, bathtubs, showers, and bath sinks (remember, kitchen sink water is not allowed to be reused) without applying for a gray water permit, **if your answer is yes to all of the following statements:**

Yes . . .

- All my gray water originates from my own residence and is used within my property boundary for household gardening, composting, lawn watering, or landscape irrigation.

- My gray water use would amount to less than 250 gallons of gray water per day (20-35 gallons per day X number of residents = the approximate amount of gray water your family creates in a day.)
- I avoid direct contact with my gray water and do not allow others to contact it directly. This means my children won't be making mudpies with this water and my pets won't play in it either.
- My gray water irrigation is only by flood or drip. I do not spray irrigate with my gray water.
- My gray water is not used on the surface for irrigation of food plants, except for fruit and nut trees.
- I don't allow my gray water to contain hazardous chemicals derived from activities such as cleaning of car parts, washing of greasy or oily rags, or disposal of waste solutions from home photo labs or home occupational activities.

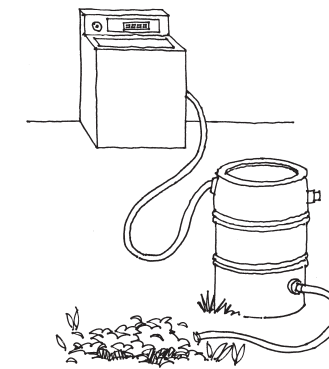

- I apply my gray water to my landscape in such a way that it minimizes standing water on the surface.
- My gray water system is constructed so that in the case of a blockage, plugging or backup of the system, all my gray water can be directed into the sewage collection system or on-site wastewater treatment and disposal system, as applicable. (The gray water system may include a means of filtration to reduce the opportunity for plugging and to extend the system lifetime.)
- If I have a gray water storage tank, it is covered to restrict access and to eliminate habitat for mosquitoes or other vectors.
- My gray water system is sited outside of any flood way.
- My gray water never comes within five feet (5') of the top of the seasonally high groundwater table.
- If I use any pressure piping in my gray water system that might be susceptible to cross connection with a potable water system, the piping is clearly marked.
- My gray water does not contain water from a washing machine that is used to wash diapers or similarly soiled or infectious garments unless that gray water is disinfected before irrigation.

Why Should You Use Your Gray Water? Because You Will . . .

- Use less of our valuable potable or fresh water.
- Save money on your water bill.
- Also, save money on your sewer bill. (Did you know that sewer bills are typically calculated based on water used during the three winter months when outdoor use is lowest?) If you irrigate during December, January and February, which many of us do to augment our less-than-dependable winter rains and snows, you cut down on the volume of potable water you use, thus reducing your sewer fees, if you irrigate with gray water.
- Have the satisfaction of taking responsibility for efficient use of a valuable, finite resource.
- Be “drought proofing” your landscape by using your gray water, since more than half of the water you use indoors can be reused as irrigation water during shortages, when outdoor watering may be restricted.
- Have a constant source of water for irrigation and your compost pile, except when you are away from home.

- Possibly be adding nutrients from your gray water beneficial to your plants and to your soil.

Do Not Use Your Gray Water If . . .

- You don’t have sufficient space or have no plants to irrigate.
- It is not possible to access your drain pipes, making gray water use uneconomical.
- Your soil is unsuitable; it won’t allow appropriate drainage and percolation of your gray water.
- Your gray water would be discharged against your house foundation, as it could cause damage to your home. Try to keep irrigation four feet from the house.
- You have a water softening system and it cannot be bypassed. The salts used to soften your water may make it unsuitable for use on some plants.
- You have a family member with an infectious health condition, or if you wash diapers and don’t treat your gray water.

If You Want to Use Your Gray Water, What Should You Do First?

If you wish to install a gray water system at your EXISTING residence, carefully consider all of the following. If you are planning a NEW residence, consider all the following, as well as the considerations for new dual plumbed residences found on page 17.

1. Read and make sure you understand the do’s and don’ts of the new Residential Gray water Reuse Rules found on page 21 of this booklet. Were you able to answer yes to all the questions posed on pages 2 and 3?
2. Determine if it is feasible for you to access your laundry water. Is your laundry located outside? In the garage? On an outside wall? The answers to these and other similar questions will help you decide.
3. Decide whether or not it is feasible to make use of your bathroom tubs and shower or sinks.

Where are your bathrooms? Are they located in the interior of the house? Are they against outside walls? The answer to these questions will be critical in determining your ability to access your gray water.

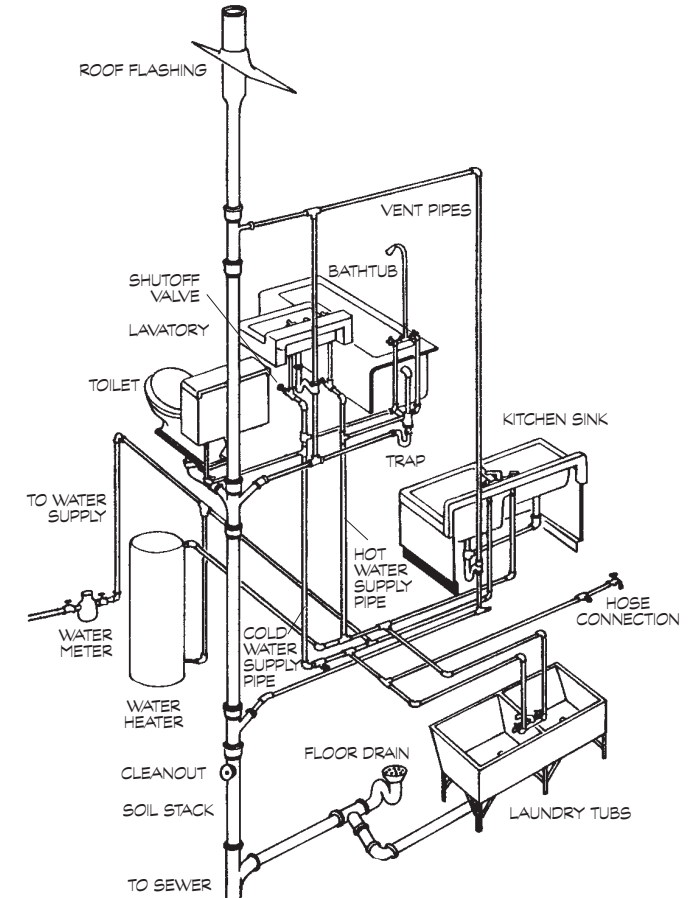

Residential Plumbing Schematic

4. Consider what plants you are going to irrigate with your gray water. Do you have special exotic plants or do you have native or desert adapted vegetation around your house? Your native plants may not need gray water year round or throughout the winter; therefore, you may wish to divert it to the sewer or to your compost during the winter months.

Where are the area(s) to be irrigated relative to the sources of your gray water? If you have laundry facilities and bathrooms in the back of your house and your garden or most of your landscaping is in the front yard, that may make your property poorly suited for gray water reuse.

5. Tapping into any part of your plumbing system has potential for creating problems, so we ask that you become

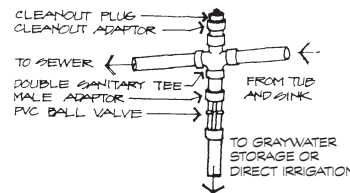
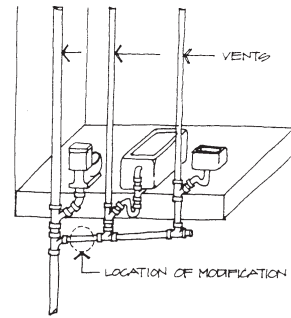

Plumbing Modifications (typical)

thoroughly familiar with your entire plumbing system before you do anything beyond considering a gray water system. If you are unsure of the intricacies of your plumbing system, particularly the drain-waste-vent portion, consult with a professional.

6. Analyze your site. Determine how much gray water your household will generate from the sources you are able to access readily. Figure your irrigation needs for existing plants in your yard or for landscaping you plan to install. Again, ask yourself where your need for gray water irrigation is relative to your gray water sources.

Plumbing Considerations

- Try to direct all irrigation water four feet (4') from your building foundation.
- Get professional advice, assistance, or have the work done by a professional if you are unsure of your expertise.
- Be sure to get your plumbing permit and inspection for changes to plumbing within your walls or to sewer and water lines.
- Use flexible or rigid pipe for pressurized gray water lines that is

color-coded either purple or gray: clearly differentiate them from your galvanized, copper or plastic drinking water supply lines.

- Put clear, bold signage on your storage tanks saying this is gray water not suitable for drinking.

What is a Gray Water System?

A gray water system can be so simple it can hardly be called a “system”: think carrying a bucket of shower water outside to water a special plant. It can also be so complex as to be completely impractical for the homeowner. Between these two extremes are many varieties of systems for irrigating with household gray water.

The goal is to find the level of system that makes maximum use of your gray water while minimizing your costs for the purchase, installation and maintenance of your system.

All gray water systems need a water source and a way to get the water from the source to the point of use. All other system components are optional and are where the major costs lie.

With gray water systems, there is no “one size fits all.” Many companies have tried to design and market such systems and they invariably fail. Be forewarned that to install a system on an existing home is more costly and more complicated than to develop a system for a new home. You may well discover that you can’t feasibly access all your gray water. Without easy access to your washing machine water, you may not be able to capture and use any of your gray water.

All that being said, it is well worth looking at how simply and easily you can make use of at least some of your gray water.

Gray Water System Components

See sample systems on pages 11-16 for a variety of combinations of the following components. There are many more systems than can be shown in this booklet, but the samples should help your thinking about what type of system would work for your particular residence.

Potential Water Sources

- Washing machines
- Bathtubs
- Showers
- Bath sinks (lavatory)
- Any combination of the above

Distribution: This is how you get the gray water to the plants. It might be a simple hose from your washing machine or an extensive drip irrigation system. You determine what this component will be by what and where you will irrigate with your gray water. You need also to consider your sources of gray water and type of storage or surge tank you will plan to utilize.

Conveyance: The conveyance portion of your system will consist of the pipes and valves needed to move the gray water from the source(s). *Any plumbing changes must conform to New Mexico state and local plumbing codes.*

Surge Tank: This vessel can range from a simple plastic trash barrel to a large, heavy-duty container which may be above ground or buried underground. The capacity can vary from less than fifty gallons to several hundred gallons, or even several thousand gallons.

This tank typically slows the water from the source(s) and allows it to mix and is applied directly to the irrigation targets. It should be labeled as containing non-potable or gray water, unfit for drinking.

For reasons of health and safety, this type of tank should only have an open top if it does not capture and store the gray water but merely allows it to surge into and then directly exit for irrigation.

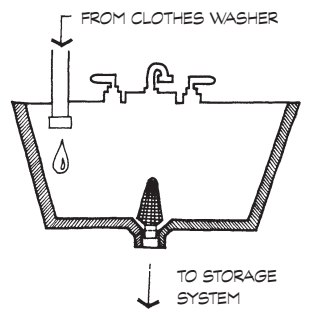

Surge Tank

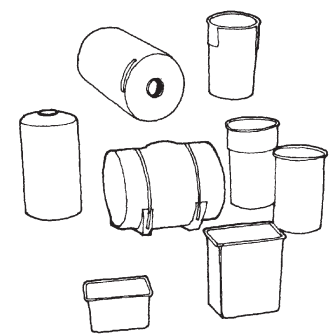

Potential Graywater Storage Tanks

Storage Tank: Like the surge tank, this vessel can vary widely in size and expense. A storage tank holds the gray water until you are ready to use it, and has an on-and-off valve for dispensing the water as needed. It should also have a valve allowing for appropriate overflow of gray water.

For reasons of health and safety, this type of tank should never have an open top: think mosquitos and curious children. Under the New Mexico law, gray water can not be stored more than 24 hours.

This tank should be labeled as containing non-potable or gray water, unfit for drinking.

Valves: A three-way or butterfly valve is a required component of any gray water system. This allows the gray water to be diverted to the sewer or septic system rather than be dispensed for irrigation. In addition, and depending upon your system design, a backflow valve may be required to ensure safety.

Overflow: Under New Mexico law, any gray water systems must include an overflow diversion to the sewer. No more than 250 gallons may be collected per day.

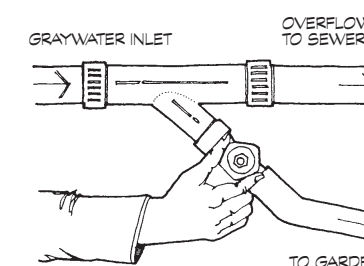

Filter: A filter is an important option for any gray water system. It is generally a good idea to catch those particles of lint, hair, etc. that you don't want out on the ground in your landscape. The simplest way to filter your gray water is to use a piece of panty hose, or a sock that has lost its mate, on the end of your drainage hose.

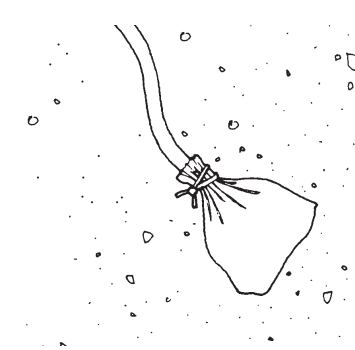

Nylon Stocking as Filter for Irrigation Hose

The advantage of this type of filter is that it can be easily discarded.

There are many other types of filters, such as screening at the point of storage, a screen in the storage tank itself, or a screen filter beyond the storage unit. Sand filtration can

also be considered for more complex systems. The need for back flushing may also be an important consideration. Take a look at the variety of filters on pages 14 and 15.

Pump: Gray water will have to be pumped at some point in the system if you cannot gravity feed your gray water to your landscape. Perhaps your gray water sources or storage tanks are not able to be located above the garden, or perhaps your garden is located above the level of the house.

The type and size of sump pump or submersible pump appropriate for your system is site- and system-specific. When selecting a pump, make sure it can handle grit, as gray water does contain particulate matter. Check with a knowledgeable person to determine what is appropriate for you.

Treatment: Make every attempt to design, install and maintain your gray water system so that it does not require the water to be treated. An occasional odor problem or murkiness in the storage tank may necessitate the use of a small amount of a swimming pool chlorine tab or a small dose of bleach or peroxide.

The following graphics are provided to convey the wide variety of systems that can be designed for retrofitting a home and to help you design and install your own system.

Gravity System

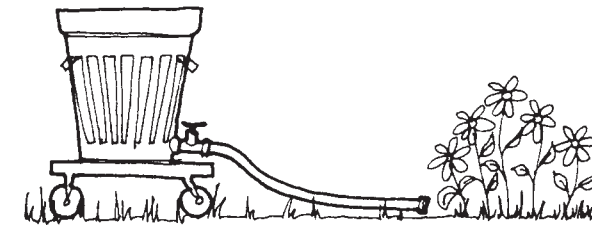
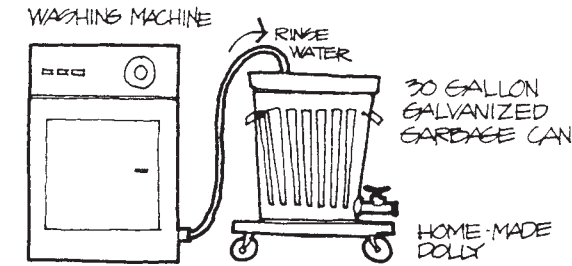

Gravity System with Portable Tank

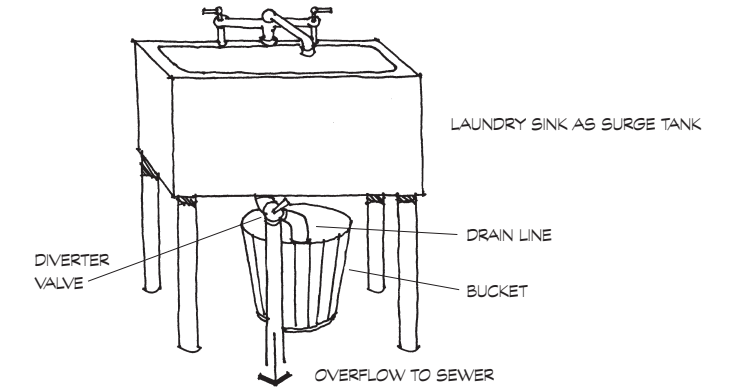

Bucket Graywater System

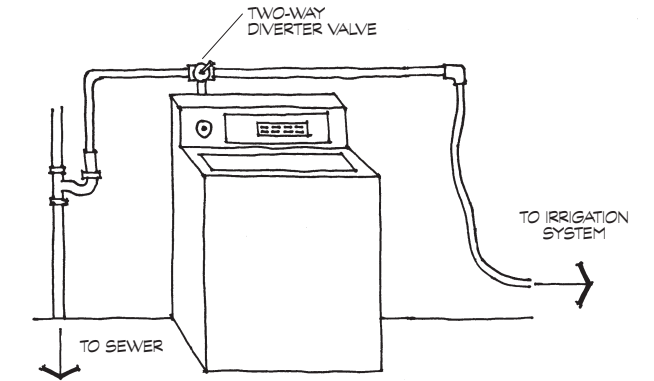

Hose Attachment Graywater System

Gravity System - continued

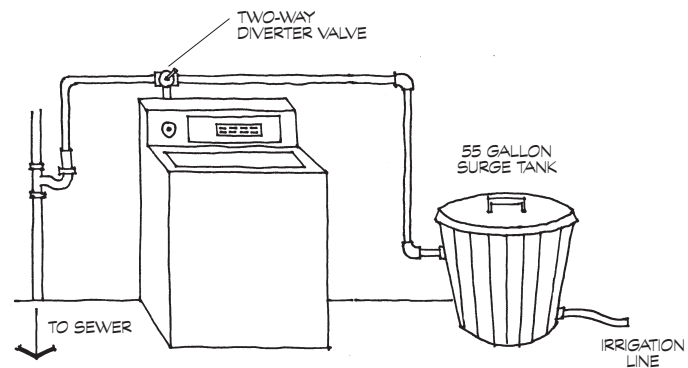

Surge Tank Graywater System

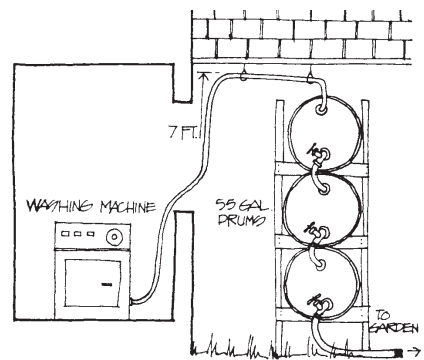

Stacked Storage Graywater System

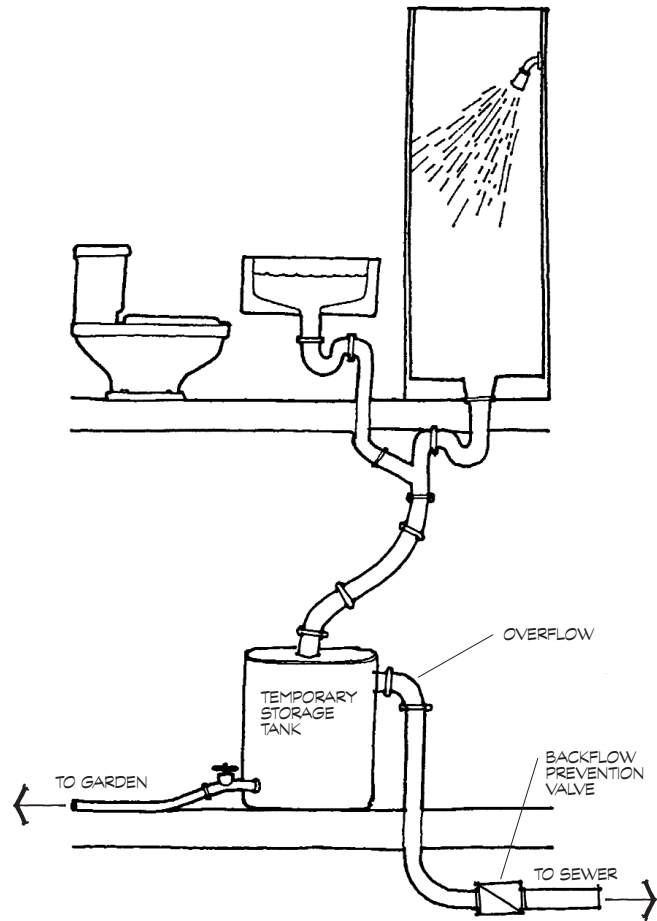

Graywater Collection from Second Story

Pump System

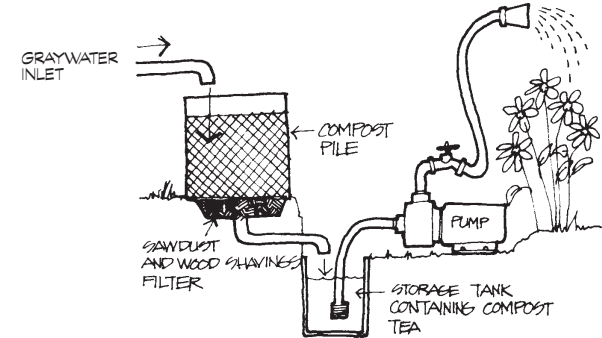

Graywater for Composting and Irrigation Pump System

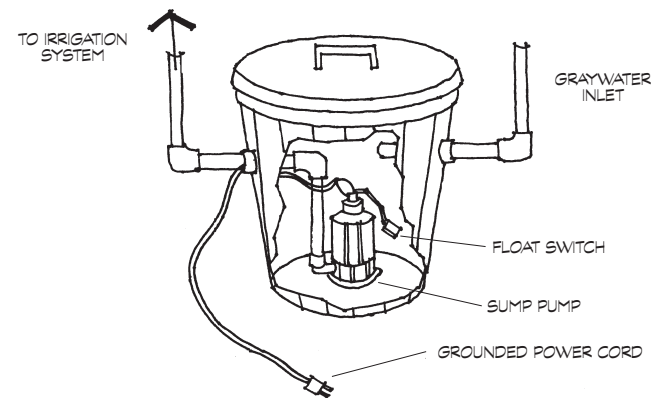

Graywater System with Distribution Pump

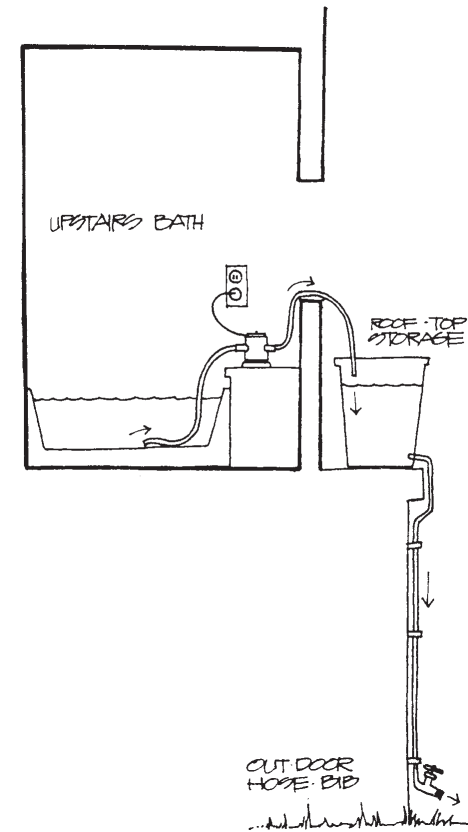

Graywater Collection from Second Story with Pump

Filters

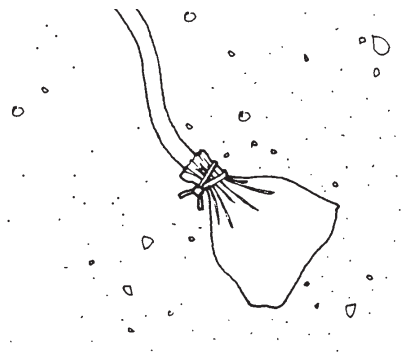

Simple Net, Stocking or Sock Filter for Irrigation Hose

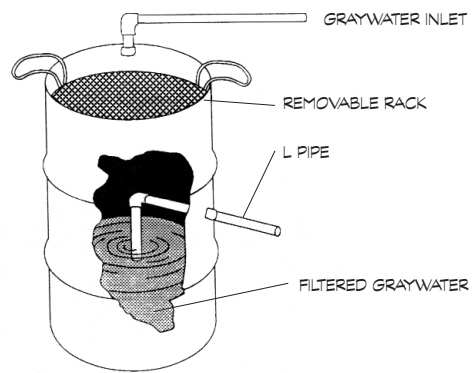

Rack Filter

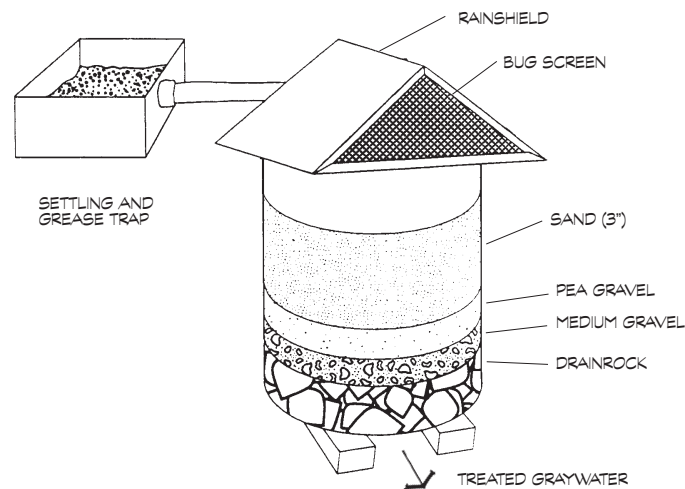

Sand Filter System

Distributor and Mixed Media Filters

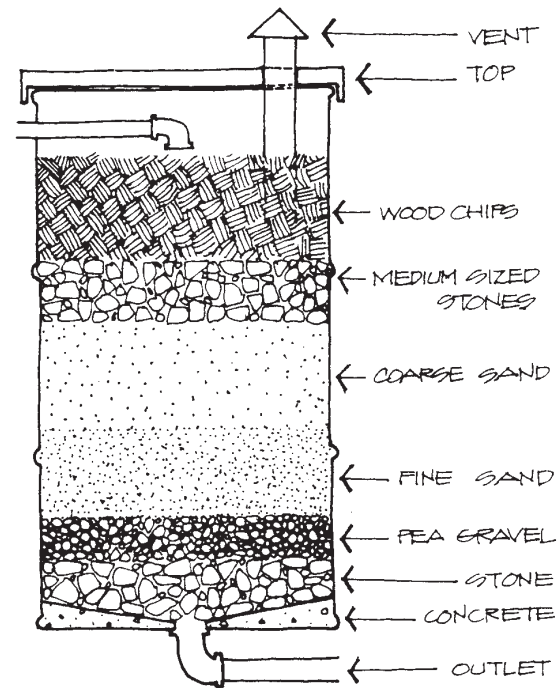

Mixed Media Filter

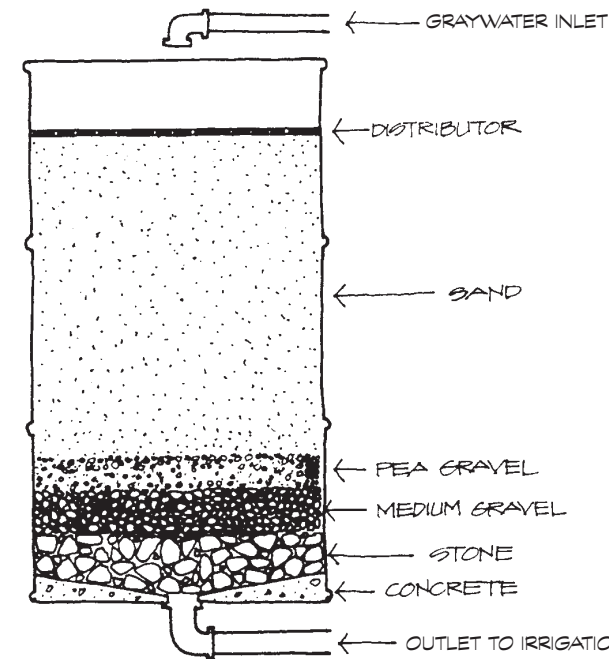

TO MAKE A DISTRIBUTOR, CUT THE TOP OF THE DRUM SO THAT IT FITS DOWN INSIDE THE DRUM. DRILL 1/2 INCH HOLES IN IT SPACED 1 INCH APART. COAT THE TOP WITH EPOXY TO PROTECT IT FROM CORROSION.

Mixed Media Filter with Distributor

Storage Tanks

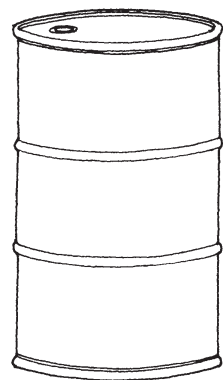

55 gallon drum

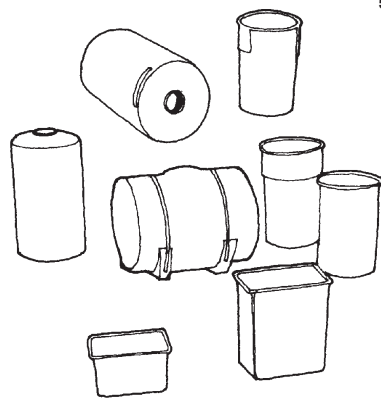

Standard Polyethylene Tanks

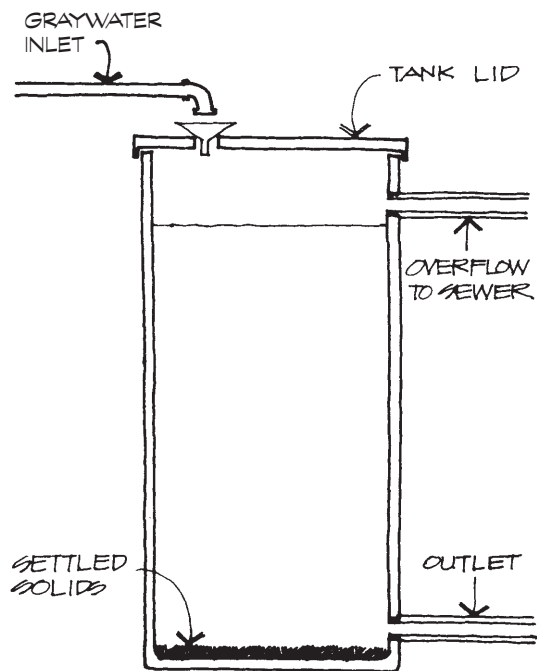

Graywater Storage (typical)

How Much Will Your Retrofit System Cost?

Washing machine hookup parts	\$25 - \$75
Shower/bath hookup parts	\$45 - \$95
Storage (50 - 500 gallons)	\$15 - \$500
(If you purchase a heavy-duty tank of greater than 50-gallon capacity, figure about a dollar a gallon for the cost of the tank.)	
Storage parts	\$50 - 150
Pump (optional)	\$90 - \$200
Total*	\$135 - \$1250

* The irrigation system is not considered in the gray water system costs.

Costs to assemble and install your system will vary greatly depending upon whether you do your own work or have it done professionally.

Additional Considerations For New Construction

To dual plumb for gray water use in any new residential construction is the simplest, most economical way to make use of your gray water.

- Read and make sure you understand the do's and don'ts of the new Residential Gray water Reuse Rules found on page 21 of this booklet. Were you able to answer yes to all the questions posed on pages 2 and 3?
- Incorporate into your design easy, but controlled, access to all sources of your gray water. (Also consider the distance from your hot water heater to where that hot water will be used. Running the faucets to get hot water creates gray water but is wasteful none-the-less.)
- Be sure your plumbing plan conforms to the Plumbing Code that is adopted and enforced by your local Building Department and to the New Mexico Residential Gray Water Rules cited at the end of this booklet
- If you design pressure piping into your gray water system, it may be subject to cross connection with a potable water system. Clearly mark that the piping does not carry potable water.

How Much Will a Gray Water System Cost in New Construction?

Piping for the dual system may add as little as \$100 - \$150 to the cost of the building project and be a strong selling point.

Storage (50 - 500 gallons)	\$15 - \$500
(If you purchase a heavy-duty tank of greater than 50-gallon capacity, figure about a dollar a gallon for the cost of the tank.)	
Storage parts	\$50 - 150
Pump (optional)	\$90 - \$200
Total*	\$65 - \$650

* The irrigation system is not considered in the gray water system costs.

How to Use Your Gray Water

Most homes produce between 20 and 35 gallons of gray water per person per day, which is about enough to water four mature fruit trees or a dozen shrubs. Given the size of your household, use these estimates to decide how you will use the amount of gray water your residence will supply.

- Consider the age and hardiness of your plants in deciding how much or how often to provide them with gray water. All plants will benefit from an occasional flushing of rainwater or tap water to remove salts and other items that may build up in the soil.
- Do not overwater your soil with gray water, or overload any sensitive plants or plant material you have recently planted.
- Deep, less frequent irrigations encourage deep, strong root systems that can tolerate longer periods of drought.
- To minimize evaporative water loss, be sure to irrigate early in the morning, preferably between 3:00 a.m. and 8:00 a.m. To do this, you will need a storage tank.
- Wait until the soil in the root zone is half dried out before you re-irrigate. To do this, you will need a storage

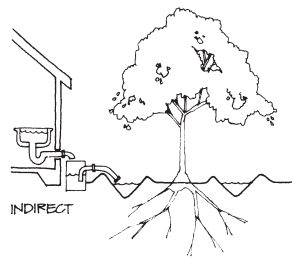
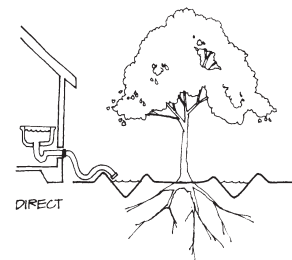

Furrow and Basin Irrigation with Graywater

tank or multiple areas on which you can use your gray water.

- Be sure you are reaching the entire depth and width of your plants' root zones. Use of a soil probe, such as a long screw-driver or a piece of re-bar will tell you how far you have moistened your soil.
- Prevent runoff. Apply water no faster than your soil can absorb it. You will need a hose bib or flow valve on your storage tank to control the rate of application.
- Use berms or basins to hold the water where you want it; allowing it to soak in for optimum use by your plants.
- Consider using your gray water subsurface in branch drains, pumice wicks or mulched basins to reduce potential contact and evaporation.
- Pay attention to what your plants are telling you. Wilted or curled leaves or leaf drop can be signs of lack of water. Brittle leaves, wilted shoot tips, or soft plant tissue can mean over watering.

Detergents and Soaps

If you plan to use washing machine water to irrigate, you need to be aware that detergents and other laundry products use a variety of chemicals to aid in cleaning. Some of these ingredients can be harmful to your plants. Consider the following product characteristics when planning your overall gray water system and how you will use the gray water you generate.

Alkalinity/Acidity - refers to the relative pH of soil. In our area, lowering the pH of the soil to make it less alkaline is generally desirable and beneficial to your plants.

Boron - considered a plant micro nutrient, required in only very, very small amounts. Most soils provide adequate amounts of this chemical. Concentrations only slightly higher than those considered beneficial can cause injury or death to plants.

Nitrogen - a very necessary nutrient for plant growth. It is extremely beneficial as a supplement to your landscape plants.

Phosphorous - a necessary plant nutrient, which is very beneficial to your landscape plants.

Potassium - a plant nutrient which is, in general, beneficial, though not as necessary in our soils as in more acidic soils

Sodium - can act as a plant poison by reducing the plant's ability to take up water from the soil. It can build up in the soil gradually increasing its toxicity, which is the last thing we need more of in our desert soils.

Chlorine - undesirable for plants in large amounts, though found in small amounts in many municipal water supplies. Bleaches and detergents carry larger amounts of chlorine, but it is generally expended in the washing process. Minimizing its contact with your garden is an important goal.

Appropriate Plant Materials For Gray Water

In general, native plants, desert-adapted plants and tough drought-tolerant plants will do best with gray water irrigation.

- Consider trees such as cottonwood, olive, locust, juniper and pinon.
- Also, shrubs such as chamisa, four winged saltbush, and privet.
- Gray water is typically alkaline so avoid using gray water on acid-loving plants.

Special Irrigation Considerations

- Disperse gray water around the yard and garden to avoid buildup of harmful ingredients
- Do not apply to potted plants or young seedlings unless you alternate with fresh water or dilute the gray water.
- Do not use gray water extensively on acid-loving plants as gray water is typically high in salts. Adding white vinegar periodically to your gray water can help lower or neutralize the pH of your water.
- If gray water is to be used for irrigation of plants with edible parts, subsurface irrigation must be used. The only exceptions are fruit and nut trees.
- Avoid using gray water on crops to be eaten raw such as lettuce.

New Mexico Gray Water Reuse Rules (effective January 2003)

Section 74-6-2 NMSA 1978 (being Laws 1967, Chapter 190, Section 2, as amended) is amended to read:

- L. shall not require a permit for applying less than two hundred fifty gallons per day of private residential gray water originating from a residence for the resident's household gardening, composting or landscape irrigation if:
1. a constructed gray water distribution system provides for overflow into the sewer system or on-site wastewater treatment and disposal system;
 2. a gray water storage tank is covered to restrict access and to eliminate habitat for mosquitoes or other vectors;
 3. a gray water system is sited outside of a floodway;
 4. gray water is vertically separated at least five feet above the ground water table;
 5. gray water pressure piping is clearly identified as a nonpotable water conduit;
 6. gray water is used on the site where it is generated and does not run off the property lines;
 7. gray water is applied in a manner that minimizes the potential for contact with people or domestic pets;
 8. ponding is prohibited, application of gray water is managed to minimize standing water on the surface and to ensure that the hydraulic capacity of the soil is not exceeded;
 9. gray water is not sprayed;

10. gray water is not discharged to a watercourse; and
11. gray water use within municipalities or counties complies with all applicable municipal or county ordinances enacted pursuant to Chapter 3, Article 53 NMSA 1978;

See the following link for the complete text of the law:

<http://legis.state.nm.us/Sessions/03%20Regular/FinalVersions/house/HB0114.pdf>

Create an Oasis With Graywater, by Art Ludwig

A complete guide to choosing, building and using gray water systems. If you buy one book about gray water, this should be it. Though it is written for a California audience, reflecting California gray water law, it is packed with good information and is a must for the gray water enthusiast. It is available from Oasis Designs at: <http://www.oasisdesign.net/>

Branched Drain Graywater System, by Art Ludwig

Reliable, sanitary, low maintenance distribution of household gray water to downhill plants without filtration or pumping. A supplement to "Create an Oasis with Graywater."

The Builder's Graywater Guide, by Art Ludwig

Installation of gray water systems in new construction and remodeling. A supplement to the book "Create an Oasis with Graywater."

Basic Plumbing Techniques, Ortho Books.

Better Homes and Gardens Handyman Book.

Uniform Plumbing Code

Residential Graywater Reuse Study, June 2000, Water Conservation Alliance of Southern Arizona. Available at <http://www.watercasa.org>.

Note:

All figures in this booklet are taken from the following publications:

Better Homes and Gardens Handyman's Book, 1970. Out of print.

Domestic Graywater: a Review of Alternatives, University of Arizona, Office of Arid Lands Study, 1992.

Graywater Use in the Landscape, Robert Kourik, 1988. Out of print.

How to Use Graywater, Santa Barbara County, 1990.

Residential Water Reuse, Murray Milne, U.C. Davis, 1979. Out of print.

Notes:

Horizontal lines for taking notes.



Original text written by Val L. Little

This publication was prepared through a joint effort by the Water Conservation Alliance of Southern Arizona, New Mexico Environment Department, New Mexico Construction Industries Division, New Mexico Office of the State Engineer, and New Mexico Cooperative Extension Service, and with the help of representatives from the building industry and local governmental organizations. Special thanks to Melissa McDonald, Santa Fe Permaculture.

**For additional copies, contact the New Mexico Office of the State Engineer,
P.O. Box 25102, Santa Fe, NM 87504; 1-800-WATER-NM, or
waternm@ose.state.nm.us.**